

K-305

WELD BEAM ATTACHMENT WITH BOLT & NUT

SIZE RANGE - 3/8" THRU 3-1/2" ROD

MATERIAL - CARBON STEEL, T-304 & T-316 STAINLESS

FUNCTION - DESIGNED FOR USE IN EITHER UPRIGHT OR INVERTED POSITION. BOLT REQUIRED WHEN WELDED TO STEEL MEMBER IN UPRIGHT POSITION.

FINISH - PLAIN, ELECTRO-GALVANIZED AND HDG

ORDER BY - FIGURE NUMBER, PIPE SIZE AND FINISH

NOTE: BOLT AND NUT INCLUDED

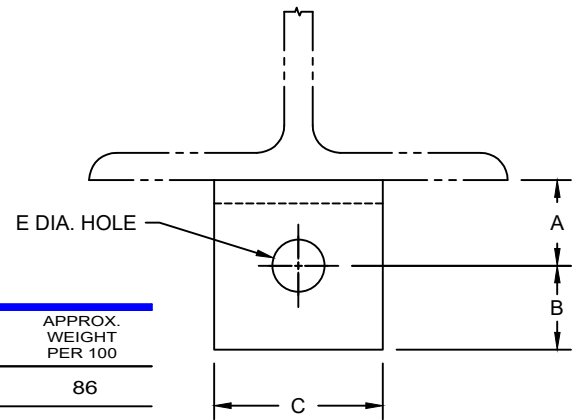
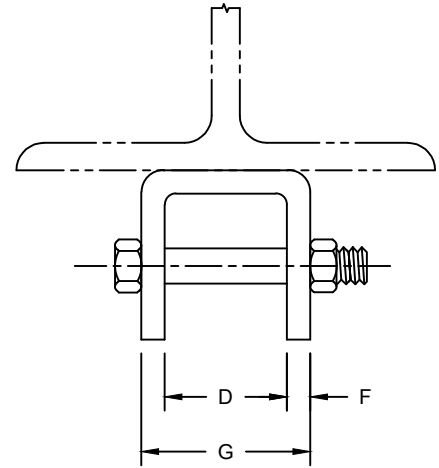

ROD SIZE	A	B	C	D	E	F	MAX REC. LOAD LBS.	APPROX. WEIGHT PER 100
3/8	2	7/8	2	1-1/4	9/16	1/4	510	86
1/2	2	7/8	2	1-1/4	11/16	1/4	940	86
5/8	2	1	2	1-1/4	13/16	1/4	1510	86
3/4	2	1-1/8	2-1/2	1-1/2	15/16	3/8	2260	174
7/8	2	1-1/4	2-1/2	2	1-1/8	3/8	3150	232
1	3	1-1/2	3	2	1-1/4	1/2	4150	394
1-1/4	3	2	4	2-1/2	1-5/8	5/8	5660	738
1-1/2	4	2-1/2	5	3	1-7/8	3/4	9700	1449
1-3/4	5	2-3/4	5	3-3/4	2-1/8	3/4	14000	1747
2	4	3-1/4	6	3-3/4	2-3/8	3/4	18460	2201
2-1/4	5	3-1/2	6	4-1/4	2-5/8	3/4	24260	2523
2-1/2	5	3-3/4	6	4-1/2	2-7/8	3/4	29880	2552
2-3/4	6	4	6	4-3/4	3-1/8	3/4	37066	2875
3	6-1/4	4	7	5-1/4	3-3/8	3/4	45085	3250
3-1/4	7	4-1/2	7	5-1/2	3-5/8	3/4	53906	4500
3-1/2	7-1/2	4-1/2	8	5-3/4	3-7/8	3/4	63493	5320