

K-30M

WELDED BRACKET MEDIUM DUTY

MAX. RECOMMENDED LOAD - 1500 LBS

MATERIAL - CARBON STEEL AND STAINLESS STEEL

FUNCTION - SPACE BETWEEN ANGLES ALLOWS SUPPORTING PIPE ON TOP OR HANGING THROUGH SUPPORT BRACKET

FINISH - PLAIN, ELECTRO-GALVANIZED AND HDG

ORDER BY - FIGURE NUMBER, SIZE, AND FINISH

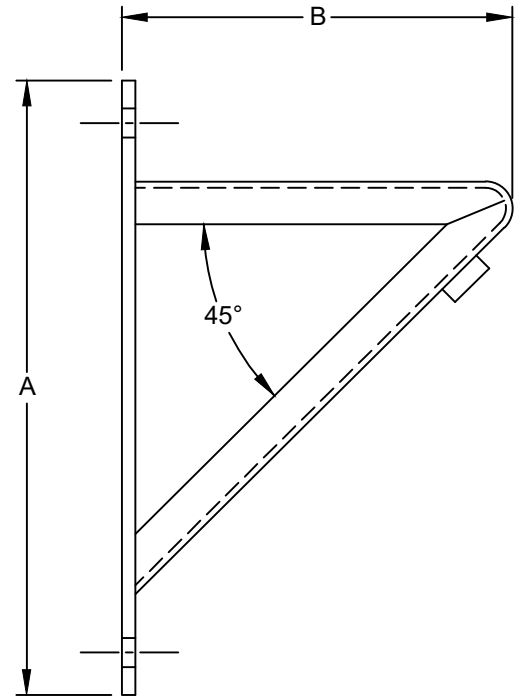

SIZE	A	B	C	D	BACK PLATE SIZE	HOLE SIZE	MAX. REC. LOAD LBS.	APPROX. WEIGHT PER 100
0	18	12	15-1/2	1-1/4	3/8 X 4	13/16	1500	1577
1	24	18	21-1/2	1-1/4	3/8 X 4-1/2	13/16	1500	2578
2	30	24	27-1/2	1-1/4	3/8 X 5	13/16	1500	4446

