

K-30L

WELDED BRACKET LIGHT DUTY

MAX. RECOMMENDED LOAD - 750 LBS

MATERIAL - CARBON STEEL AND STAINLESS STEEL

FUNCTION - SPACE BETWEEN ANGLES ALLOWS SUPPORTING PIPE ON TOP OR HANGING THROUGH SUPPORT BRACKET

FINISH - PLAIN, ELECTRO-GALVANIZED AND HDG

ORDER BY - FIGURE NUMBER, SIZE, AND FINISH

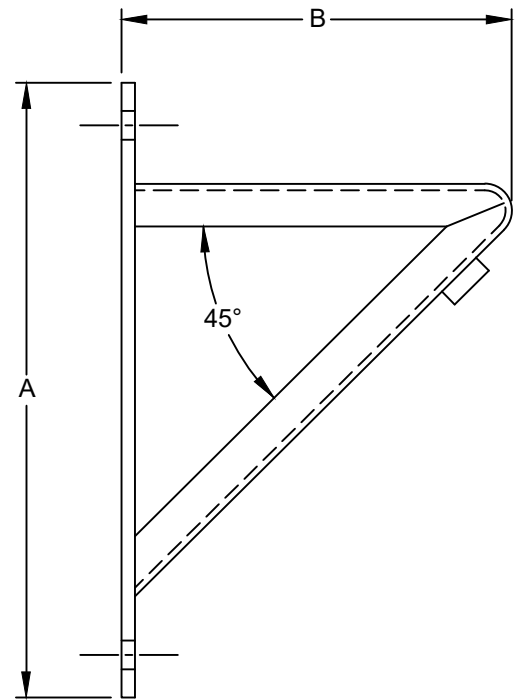

SIZE	A	B	C	D	BACK PLATE SIZE	HOLE SIZE	MAX. REC. LOAD LBS.	APPROX. WEIGHT PER 100
1	13	9	11-1/2	1-1/4	1/4 X 3	9/16	750	571
2	17	13	15-1/2	1-1/4	1/4 X 3	9/16	750	769
3	23	19	21-1/2	1-1/4	1/4 X 3	9/16	750	1057

