

# K-30

## LIGHT WELDED BRACKET

SIZE RANGE - 9", 13" AND 19"

MATERIAL - CARBON STEEL AND STAINLESS STEEL

FUNCTION - FOR SUSPENDING PIPE OUTWARD FROM MOUNTING SURFACE.

MAXIMUM RECOMMENDED LOAD - 500 LBS

SIZE RANGE - DESIGNED TO SUPPORT UP TO 3-1/2" STANDARD PIPE

FINISH - PLAIN, ELECTRO-GALVANIZED AND HDG

ORDER BY - FIGURE NUMBER, INDICATE "A" AND "H" DIMENSIONS, AND FINISH

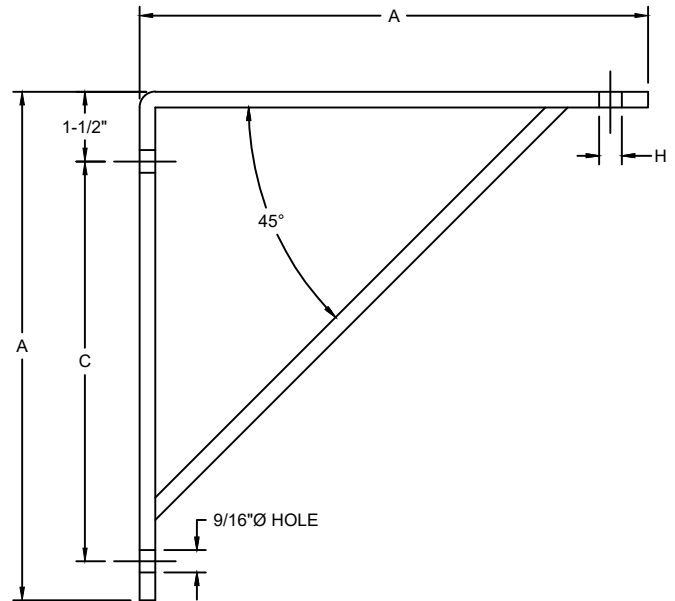

| A  | B  | C      | H          | MAXIMUM<br>REC. LOAD LBS |
|----|----|--------|------------|--------------------------|
| 9  | 8  | 6-1/2  | 3/8 OR 1/2 | 500                      |
| 13 | 12 | 10-1/2 | 3/8 OR 1/2 | 500                      |
| 19 | 18 | 16-1/2 | 3/8 OR 1/2 | 500                      |