

K-110 DI

DUCTILE IRON PIPE U-BOLT

SIZE RANGE - 1/2" THRU 36" PIPE

MATERIAL - CARBON STEEL AND STAINLESS STEEL

FUNCTION - RECOMMENDED FOR SUPPORT, ANCHOR OR GUIDE OF HEAVY LOADS, OFTEN EMPLOYED IN POWER AND PROCESS PLANT SERVICE

FINISH - PLAIN, ELECTRO-GALVANIZED, HDG

ORDER BY - FIGURE NUMBER, ROD SIZE X PIPE SIZE (AS 5/8 X 6)
 U-BOLT CAN BE FURNISHED WITH LONGER TANGENTS "D" OR WITH LONGER THREADS "E", IF SO REQUIRED.

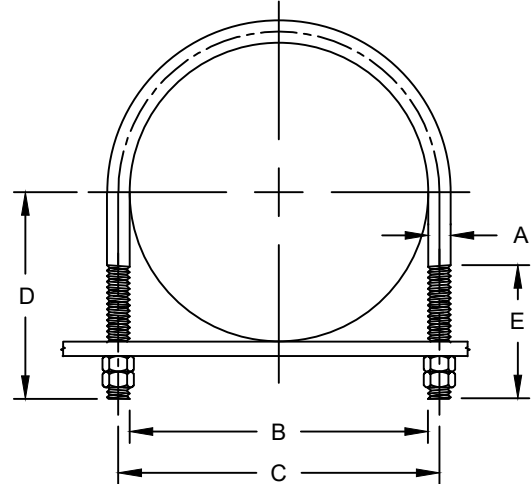

PIPE SIZE	PIPE O.D.	A ROD SIZE	B	C	D	E	MAX. REC. LOAD LBS* FOR SERVICE TEMPS.		APPROX. WEIGHT PER 100
							650°F	750°F	
3	3.96	1/2	4-1/16	4-3/16	4-1/2	3	2260	2020	93
4	4.80	1/2	5	5-1/2	5	3	2260	2020	110
6	6.90	5/8	7-1/16	7-11/16	6-1/4	3-3/4	3620	3230	200
8	9.05	5/8	9-3/16	9-13/16	7-1/2	3-3/4	3620	3230	230
10	11.10	3/4	11-1/4	12	9	4	5420	4830	486
12	13.05	7/8	13-3/8	14-1/4	10-1/2	4-1/2	7540	6730	790
14	15.30	7/8	15-1/2	16-3/8	11	4-1/2	7540	6730	850
16	17.40	7/8	17-9/16	19-5/16	12	4-1/2	7540	6730	935
18	19.05	1	20	21	14	5	9920	8850	1360
20	21.60	1	21-1/8	22-1/8	16	5	9920	8850	1476
24	25.80	1	26-3/8	27-3/8	17-1/2	6	9920	8850	1698
30	32.00	1	32-1/2	33-1/2	20	6	9920	8850	2027
36	38.30	1	38-1/8	39-7/8	23	6	9920	8850	2320