

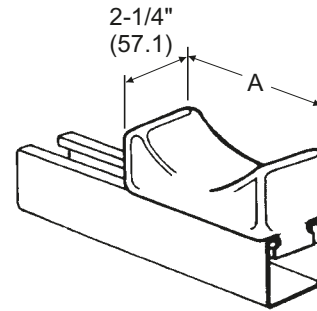

PORCELAIN CABLE SADDLES

CATALOG NUMBER	"A" LENGTH		MAXIMUM CABLE DIA.		WEIGHT PER 100	
	in	mm	in	mm	lbs	kg
N-2708	3	76.2	3	76.2	73	33.1
N-2709	4	101.6	4-1/2	114.3	104	47.2



MAPLE CABLE SADDLES

CATALOG NUMBER	HOLE SIZE (CABLE DIA.)		"A" LENGTH		"B" LENGTH		WEIGHT PER 100	
	in	mm	in	mm	in	mm	lbs	kg
N-2810	0 - 1	0 - 25.4	3	76.2	1-3/4	44.4	30	13.6
N-2811	1 - 1-1/2	25.4 - 38.1	3-1/2	88.9	2	50.8	40	18.1
N-2812	1-1/2 - 2	38.1 - 50.8	4	101.6	2-1/4	57.1	50	22.7
N-2813	2 - 2-1/2	50.8 - 63.5	4-1/2	114.3	3-1/2	88.9	70	31.7
N-2814	2-1/2 - 3	63.5 - 76.2	5	127.0	2-3/4	69.8	80	36.3
N-2815	3 - 3-1/2	76.2 - 88.9	5-1/2	139.7	3	76.2	100	45.4
N-2816	3-1/2 - 4	88.9 - 101.6	6	152.4	3-1/4	82.5	130	59.0
N-2817	4 - 4-1/2	101.6 - 114.3	7	177.8	3-3/4	95.2	160	72.6

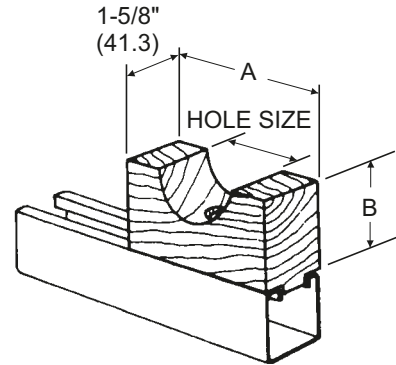

Furnished with 2 studs, 2 hex nuts, 2 flat washers. Requires two 3/8" clamping nuts. Maple hardwood parafin impregnated. Order separately. Orders must specify exact hole size.

SQUARE MAPLE CABLE CLAMPS

CATALOG NUMBER	HOLE SIZE		"A" LENGTH		"B" LENGTH		STUD SIZE	WEIGHT PER 100	
	in	mm	in	mm	in	mm		lbs	kg
N-2820	0 - 1	0 - 25.4	3-1/2	88.9	3-1/2	88.9	3/8"-16x6	68	30.9
N-2821	1 - 1-1/2	25.4 - 38.1	4	101.6	4	101.6	3/8"-16x6	88	40.0
N-2822	1-1/2 - 2	38.1 - 50.8	4-1/2	114.3	4-1/2	114.3	3/8"-16x7	106	48.1
N-2823	2 - 2-1/2	50.8 - 63.5	5-1/2	139.7	5-1/2	139.7	3/8"-16x8	146	66.3
N-2824	2-1/2 - 3	63.5 - 76.2	6	152.4	6	152.4	3/8"-16x8	188	85.4
N-2825	3 - 3-1/2	76.2 - 88.9	6-1/2	165.1	6-1/2	165.1	3/8"-16x9	223	101.2
N-2826	3-1/2 - 4	88.9 - 101.6	7	177.8	7	177.8	3/8"-16x9	259	117.6
N-2827	4 - 4-1/2	101.6 - 114.3	7-1/2	190.5	7-1/2	190.5	3/8"-16x10	276	125.3

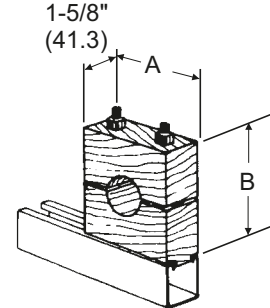

Furnished with 2 studs, 2 hex nuts, 2 flat washers. Requires two 3/8" clamping nuts. Maple hardwood parafin impregnated. Order separately. Orders must specify exact hole size.

MAPLE CABLE CLAMPS

CATALOG NUMBER	HOLE SIZE		"A" LENGTH		PIPE CLAMP INCLUDED	WEIGHT PER 100	
	in	mm	in	mm		lbs	kg
N-2870	0 - 5/8	0 - 15.9	1	25.4	N-2130	24	10.9
N-2871	1/2 - 1	12.7 - 25.4	1-1/2	38.1	N-2134	43	19.5
N-2872	3/4 - 1-1/2	19.0 - 38.1	2	50.8	N-2138	54	24.5
N-2873	1-1/4 - 1-3/4	31.7 - 44.4	2-1/2	63.5	N-2142	66	30.0
N-2874	1-1/2 - 2-1/4	38.1 - 57.1	3	76.2	N-2146	85	38.6
N-2875	2 - 2-1/2	50.8 - 63.5	3-1/2	88.9	N-2150	108	49.0
N-2876	2-1/4 - 3	57.1 - 76.2	4	101.6	N-2154	123	55.8
N-2877	3 - 4	76.2 - 101.6	5	127.0	N-2162	163	74.0

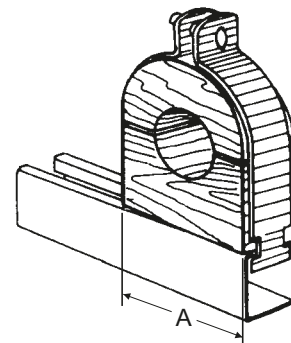

Maple Cable Clamps are furnished complete with pipe clamp and hardware.